

MAXIMUM LOAD CONDITIONS

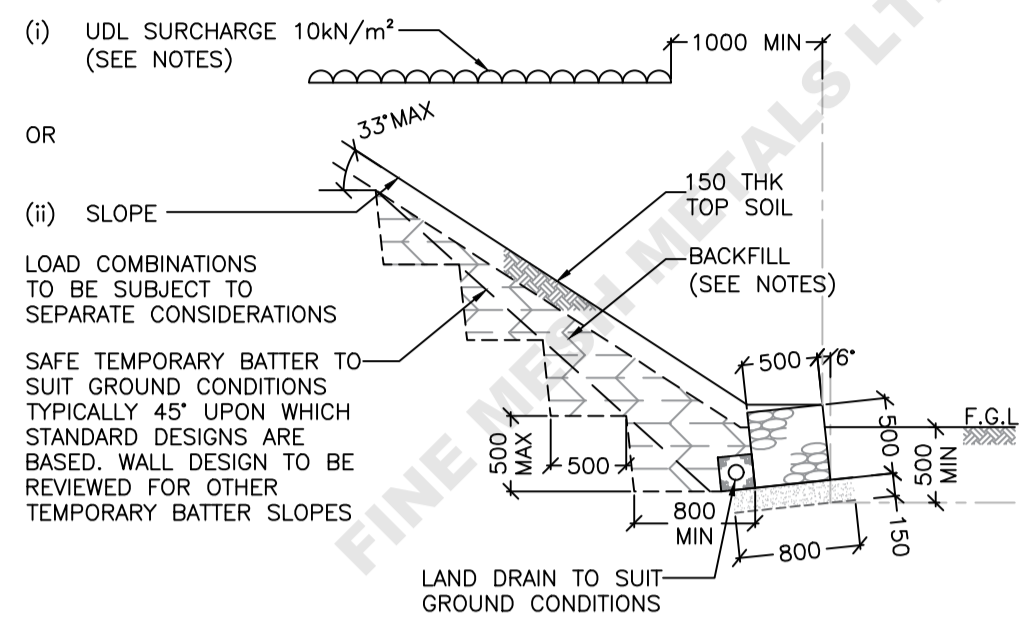

FOUNDATION SOILS
COHESIONLESS I.E. SANDS, GRAVELS - INSITU STATE
NOT LESS THAN LOOSE I.E. CANNOT BE EXCAVATED WITH
A SPADE, 50mm PEG EASILY DRIVEN.

COHESIVE SOILS I.E. MINIMUM FIRM CLAYS - PLASTICITY
INDEX (I_p) NOT GREATER THAN 23%

MAXIMUM IMPOSED FOUNDATION PRESSURES
SLS - 10 KN/M²
ULS - 13 KN/M²

WALL HEIGHT - 0.5m
(SEE TYPICAL CONSTRUCTION DETAILS
FOR GENERAL CONSTRUCTION DETAILS)

MAXIMUM LOAD CONDITIONS

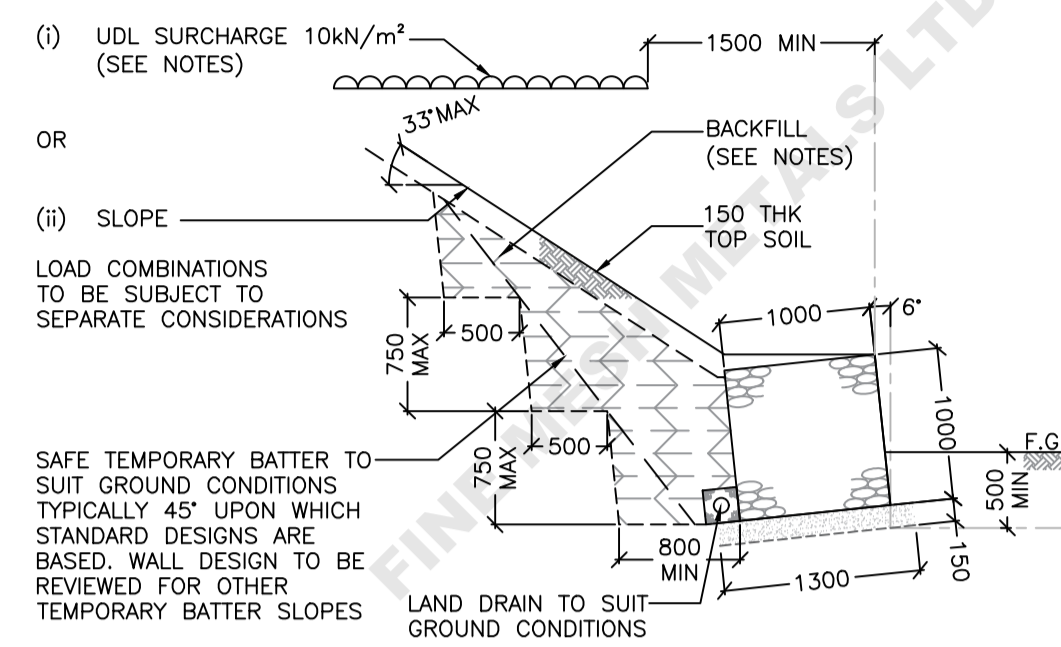

FOUNDATION SOILS
COHESIONLESS I.E. SANDS, GRAVELS - INSITU STATE
NOT LESS THAN LOOSE I.E. CANNOT BE EXCAVATED WITH
A SPADE, 50mm PEG EASILY DRIVEN.

COHESIVE SOILS I.E. MINIMUM FIRM CLAYS - PLASTICITY
INDEX (I_p) NOT GREATER THAN 23%

MAXIMUM IMPOSED FOUNDATION PRESSURES
SLS - 18 KN/M²
ULS - 20 KN/M²

WALL HEIGHT - 1.0m
(SEE TYPICAL CONSTRUCTION DETAILS
FOR GENERAL CONSTRUCTION DETAILS)

MAXIMUM LOAD CONDITIONS

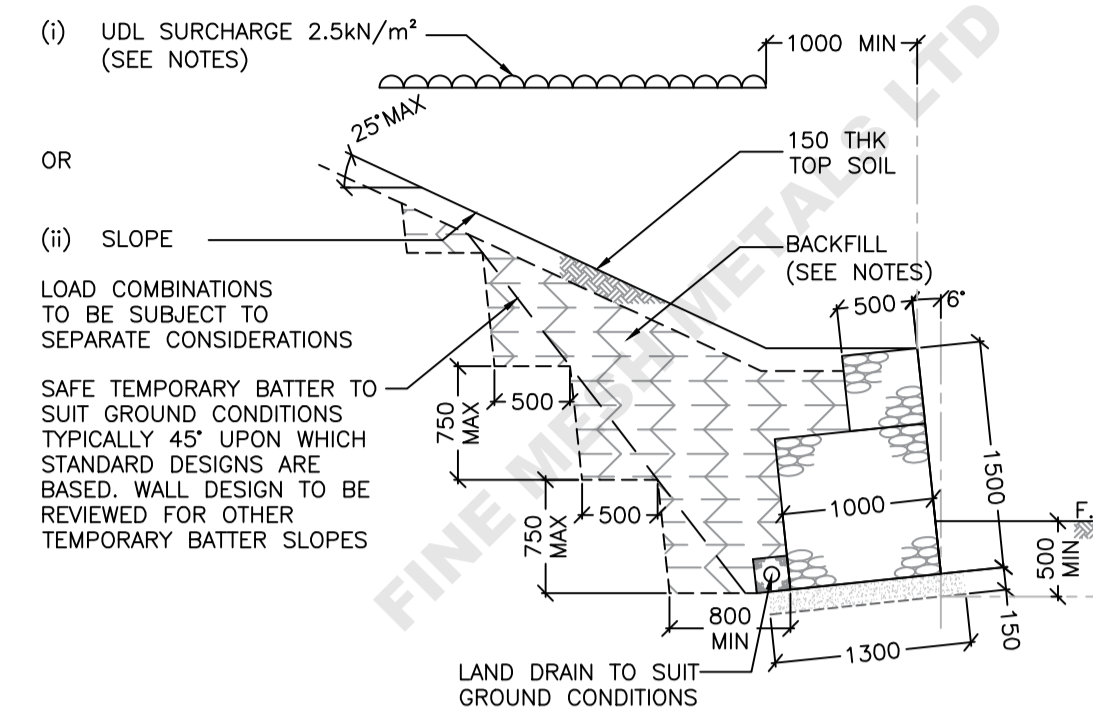

FOUNDATION SOILS
COHESIONLESS I.E. SANDS, GRAVELS - INSITU STATE
NOT LESS THAN LOOSE I.E. CANNOT BE EXCAVATED WITH
A SPADE, 50mm PEG EASILY DRIVEN.

COHESIVE SOILS I.E. MINIMUM FIRM CLAYS - PLASTICITY
INDEX (I_p) NOT GREATER THAN 23%

MAXIMUM IMPOSED FOUNDATION PRESSURES
SLS - 36 KN/M²
ULS - 48 KN/M²

WALL HEIGHT - 1.5m
(SEE TYPICAL CONSTRUCTION DETAILS
FOR GENERAL CONSTRUCTION DETAILS)

MAXIMUM LOAD CONDITIONS

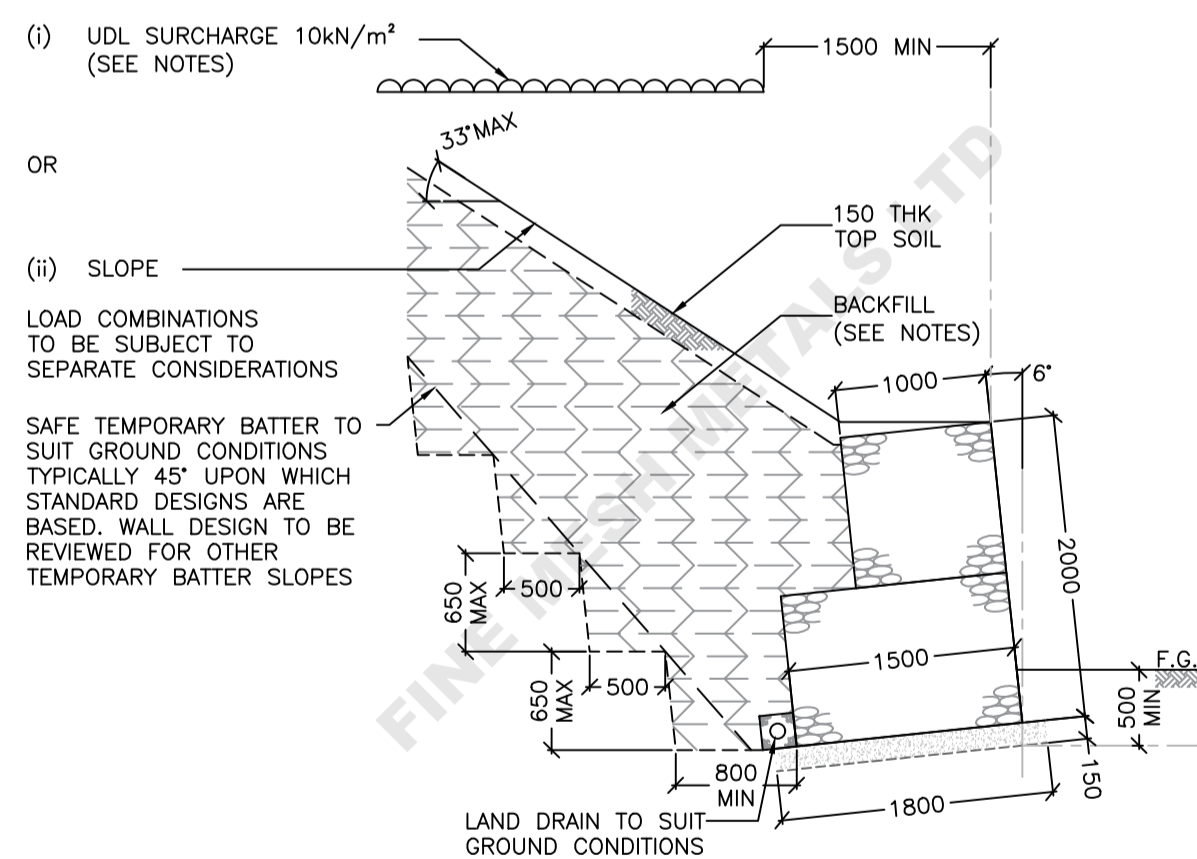

FOUNDATION SOILS
COHESIONLESS I.E. SANDS, GRAVELS - INSITU STATE
NOT LESS THAN LOOSE I.E. CANNOT BE EXCAVATED WITH
A SPADE, 50mm PEG EASILY DRIVEN.

COHESIVE SOILS I.E. MINIMUM FIRM CLAYS - PLASTICITY
INDEX (I_p) NOT GREATER THAN 23%

MAXIMUM IMPOSED FOUNDATION PRESSURES
SLS - 45 KN/M²
ULS - 57 KN/M²

WALL HEIGHT - 2.0m
(SEE TYPICAL CONSTRUCTION DETAILS
FOR GENERAL CONSTRUCTION DETAILS)

MAXIMUM LOAD CONDITIONS

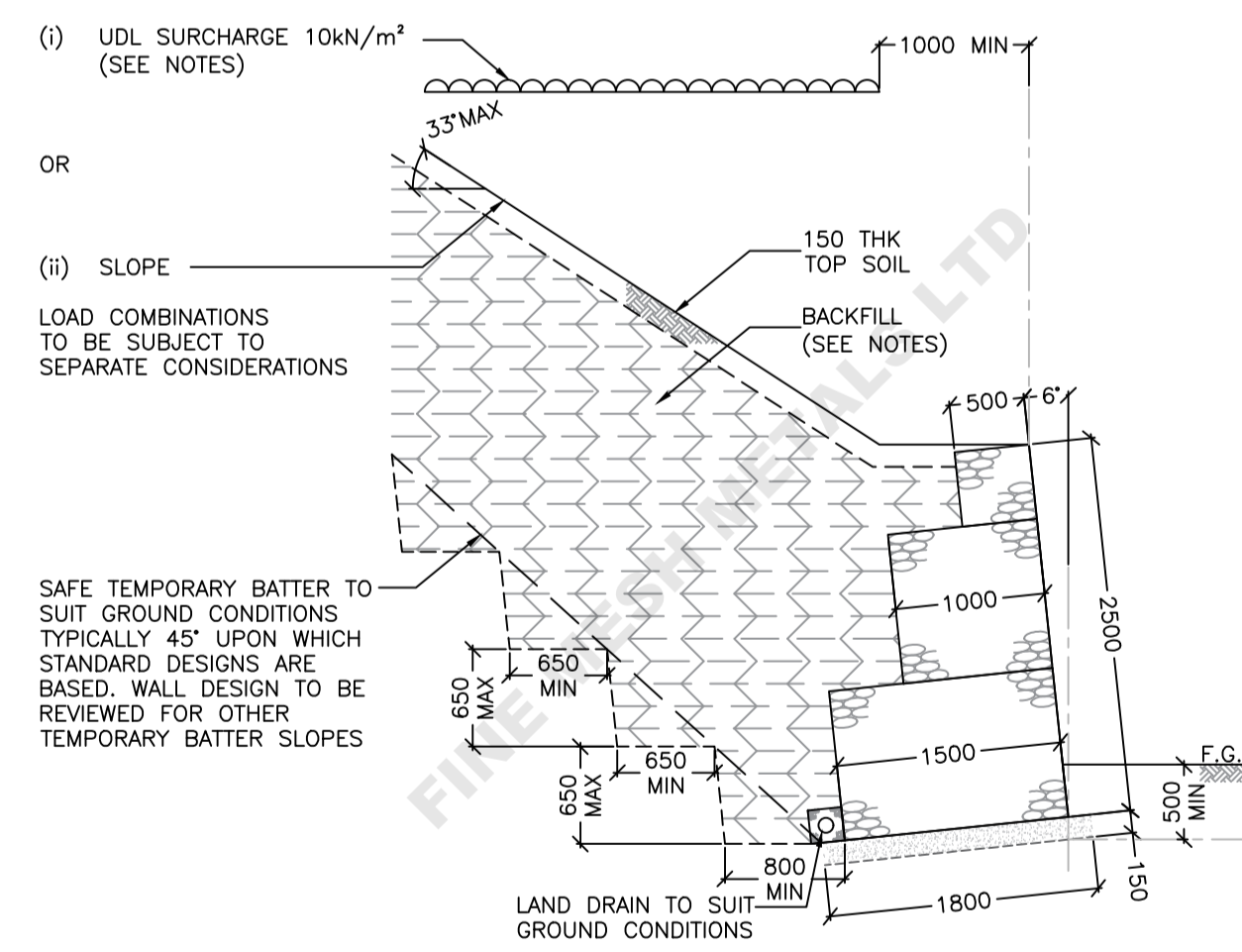

FOUNDATION SOILS
COHESIONLESS I.E. SANDS, GRAVELS - INSITU STATE
NOT LESS THAN LOOSE I.E. CANNOT BE EXCAVATED WITH
A SPADE, 50mm PEG EASILY DRIVEN.

COHESIVE SOILS I.E. MINIMUM FIRM CLAYS - PLASTICITY
INDEX (I_p) NOT GREATER THAN 23%

MAXIMUM IMPOSED FOUNDATION PRESSURES
SLS - 67 KN/M²
ULS - 99 KN/M²

WALL HEIGHT - 2.5m
(SEE TYPICAL CONSTRUCTION DETAILS
FOR GENERAL CONSTRUCTION DETAILS)

MAXIMUM LOAD CONDITIONS

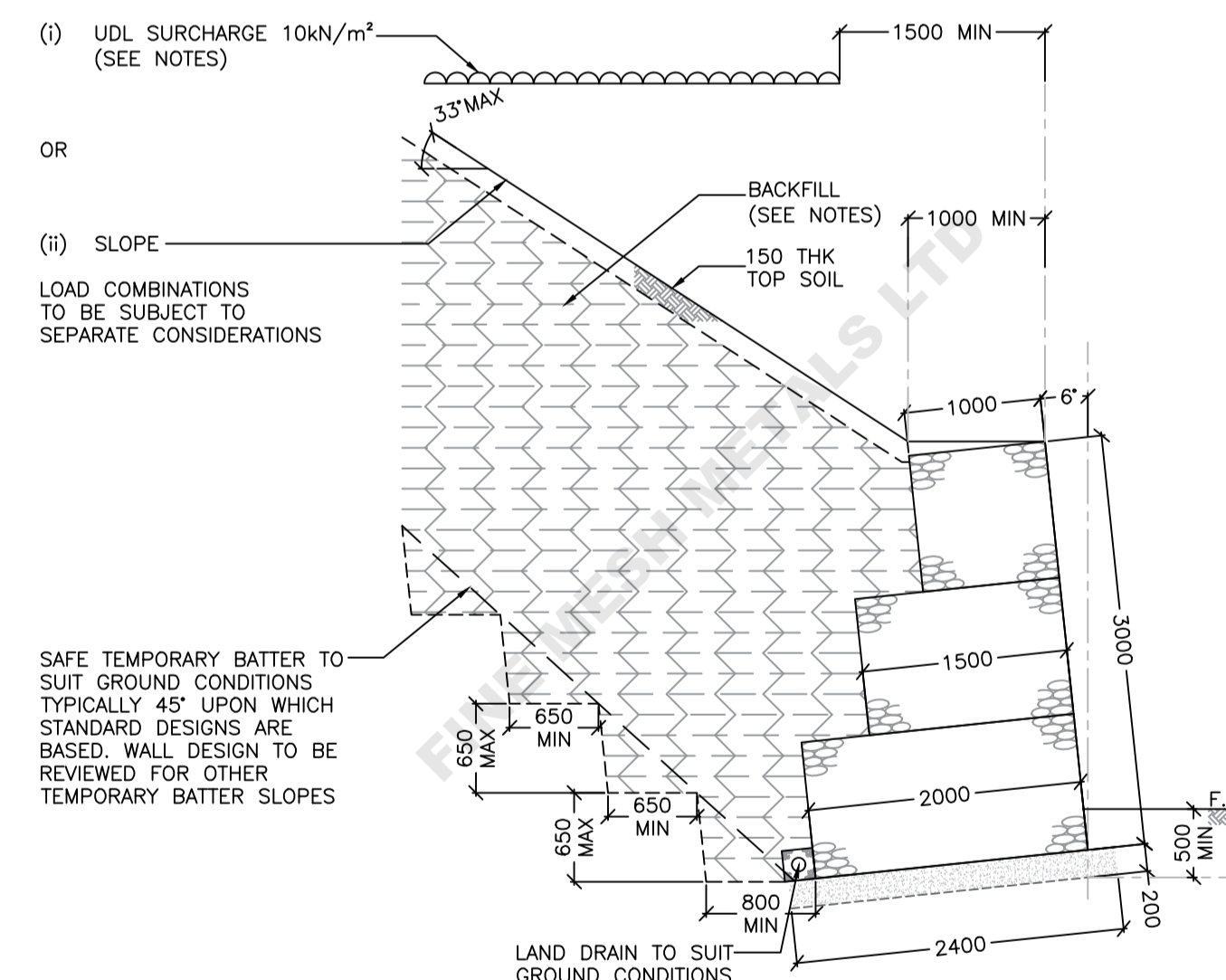

FOUNDATION SOILS
COHESIONLESS I.E. SANDS, GRAVELS - INSITU STATE
NOT LESS THAN LOOSE I.E. CANNOT BE EXCAVATED WITH
A SPADE, 50mm PEG EASILY DRIVEN.

COHESIVE SOILS I.E. MINIMUM FIRM CLAYS - PLASTICITY
INDEX (I_p) NOT GREATER THAN 23%

MAXIMUM IMPOSED FOUNDATION PRESSURES
SLS - 65 KN/M²
ULS - 92 KN/M²

WALL HEIGHT - 3.0m
(SEE TYPICAL CONSTRUCTION DETAILS
FOR GENERAL CONSTRUCTION DETAILS)

NOTES:

1. IF IN DOUBT ASK
2. All dimensions must be checked on site and not scaled from this Drawing.
3. All dimensions shown on this drawing are in millimetres unless stated otherwise.
4. All levels shown on this drawing are in metres unless stated otherwise.
5. This Drawing is to be read in conjunction with all other relevant Drawings.
6. The design shown on this Drawing has been prepared in accordance with the levels, dimensions, details and soil conditions noted. In the event that any of these are found to vary from that shown INTEC CONSULTING must be notified immediately.
7. The side of the excavations and any temporary earthworks profiles are to be regularly inspected to ensure that they remain stable and are not deteriorating through the ingress of water or ground water seepage or any other means and the works can be constructed safely at all times.
8. All services on the area of the works are to be located and clearly marked prior to the works commencing.
9. Gabions are to be installed in accordance with manufacturer's instructions.
10. All gabion panel intersections are to be laced with wire matching the gabion mesh.
11. Internal bracing wires are to be provided to exposed faces. Wire to match gabion mesh. Wire to be provided at 1/3 and 2/3 gabion height for 1.0m high gabions and 1/2 height for 0.5m high gabions.
12. Gabion infill stone shall be hard and durable and 150mm nominal size but not less than 100mm and not greater than 200mm.
13. Gabion infill stone shall be angular and placed flat to minimise voids and provide a dense stable mass. Gabion stone shall be hand picked after placing by machine. Stones to the front shall be selected and hand placed to provide a neat finish.
14. Gabion sizes are nominal and are 2.0m nominal length. Actual sizes are to the nearest 3 inches. For further details contact Fine Mesh Metals Ltd.

15. Gabions to be welded mesh 76.2 x 76.2 x 3.4 or 5mmØ wire. Galvan corrosion protection coating as Fine Mesh Metals Ltd.
- 3.0 dia wire for walls up to and including 3.0m high.
- 4.0 dia wire to face panels to top three rows throughout the subsequent rows for walls greater than 3.0m high.
16. Formation to be proof rolled with a dead weight roller min. weight 2 tonnes to identify any soft spots which are to be excavated and filled with Type 1 granular sub base material compacted in layers n/e 150mm thickness
17. Backfill material shall comprise a well graded granular material max. particle size 40mm, uniformity coefficient greater than 10 and at moisture content to ensure a dense stable compacted state SHW 6N.
18. The size of compaction plant used within a distance of 2.0 metres from the rear of the retaining wall shall have a dead weight not greater than 1000kg.
19. UDL (uniformly distributed load) surcharge.

Type:	Taken As: (KN/M ²)
Domestic pedestrian	1.50
Vehicle traffic areas (Gross vehicle weight less than 3 tonnes)	2.50
Vehicle traffic areas (Gross vehicle weight greater than 3 tonnes but less than 16 tonnes)	5.00

20. Gabion retaining walls are flexible structures. The design of adjacent vehicle trafficked areas should be prepared accordingly.
21. Global Stability - Subject to embankment / wall arrangement and in situ soils, the overall stability of the embankment / wall arrangement i.e. global stability should be checked to ensure satisfactory stability.
22. Foundation bearing pressures key:
Serviceability limited state - SLS
Ultimate limit state - ULS
23. Rows can be stepped back e.g 150mm or finished with a flush face as shown.
24. For installations where ground water seepage is encountered from retained soils or where the wall is subject to flooding consideration should be given to the incorporation of a geotextile filter membrane as Terram T1000 or similar to the rear of the wall. For further assistance contact Fine Mesh Metals Ltd.

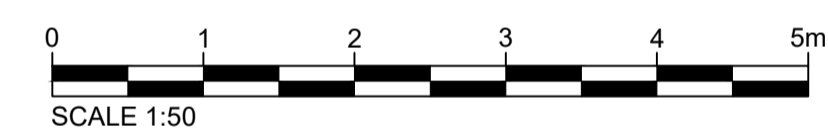

REV	DATE	REVISIONS
C	19.08.18	CLASSIFICATION FOR COHESIVE FOUNDATION SOILS AMENDED
B	29.08.18	MINOR AMENDMENTS
A	23.08.18	FOR APPROVAL
P2	31.07.18	STANDARD DETAILS ADDED TO ALL SECTIONS

INTEC CONSULTING
The Rosary, Longdon, Tewkesbury, Glos, GL20 6AS
Tel: 01684 833874
e-mail: info@intec-consulting.co.uk
www.intec-consulting.co.uk

CLIENT
FINE MESH METALS LTD

JOB TITLE
GABION EARTH RETAINING WALLS

DRAWING TITLE
STANDARD DESIGNS DESIGN DETAILS

SCALE AS SHOWN
STATUS FOR APPROVAL
DATE JUN 2018 DRAWN BY RW (CMD)

DRAWING NO.	REV
C10487/02	C

DESIGN ARRANGEMENTS
SCALE: 1/50